

# CONNEXT POST

Ready to install posts and components for your food protection system.



Protected by one or more of the following US Patents:  
10,292,506  
10,413,097



# Welcome To Connekt

Many commercial foodservice applications require protective barriers for product, food, staff, and their customers. Our lines of sneeze guards/food shields and display case hardware include glass connectors and kits that offer the ability to create your own hygienic barrier solution that meets your custom layout and vision.

## Connekt Features:

- Precision-machined components from aircraft grade aluminum
- Guaranteed food-safe, NSF-certified hardware
- Our elegant, unobstructive, patented system is trusted by leading brands worldwide
- Everything but the glass - build a custom food shield using your own acrylic or tempered glass (Don't worry, we give you glass drawings, guidelines and specifications)
- Bulk pricing with easy online purchasing and fast shipping
- Assembled, packaged, and shipped in the United States

## About Connekt Post

Connekt Post provides out-of-the-box, premium, durable posts and components that are ready to install in order to build a food protection system with your tempered glass panels and countertop surface.

## Table of Contents

- 3 | Posts
- 7 | Model(s)

# POSTS

## V1 - ADJUSTABLE FOOD SHIELD

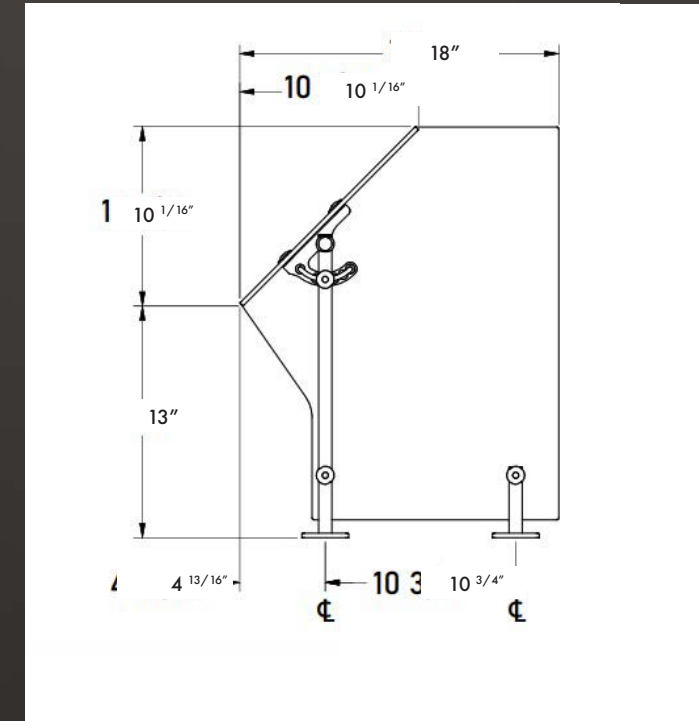

### V1-LF



Compatible with model(s): V1, V1D

### V1-RF



Compatible with model(s): V1, V1D

### V1-LFE



Compatible with model(s): V1E, V1ED



**V1-RFE**



Compatible with model(s): V1D, V1ED

**V1-CF**



Compatible with model(s): V1E, V1ED

**V2 - SELF-SERVICE FOOD SHIELD WITH TOP SHELF**

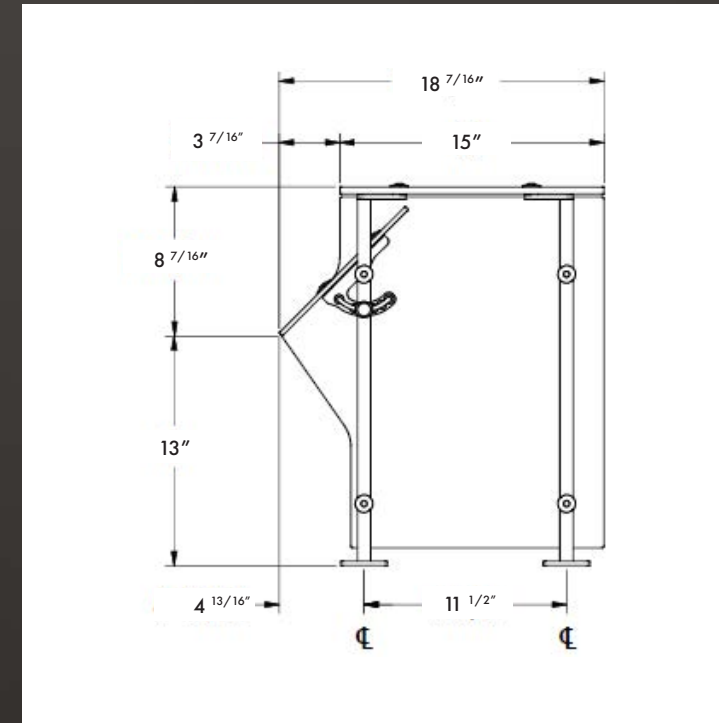

**V2-R**



Compatible with model(s): V2, V2D

**VEPS**



Compatible with model(s): V1E, V1ED, V5E, V5ED, V6E, V6ED

**V23-LF**



Compatible with model(s): V2, V2D, V3, V3D

**V23-RF**



Compatible with model(s): V2, V2D, V3, V3D

**V23-CF**



Compatible with model(s): V2D, V2ED, V3D, V3ED

**V23-CF**



Compatible with model(s): V2D, V2ED

**V23-LFE**



Compatible with model(s): V2E, V2ED, V3E, V3ED

**V23-RFE**



Compatible with model(s): V2E, V2ED, V3E, V3ED

**V2-LRE**



Compatible with model(s): V2E, V2ED

**V2-RRE**



Compatible with model(s): V2E, V2ED

**V4 - ENCLOSED OPERATOR-SERVE FOOD SHIELD**

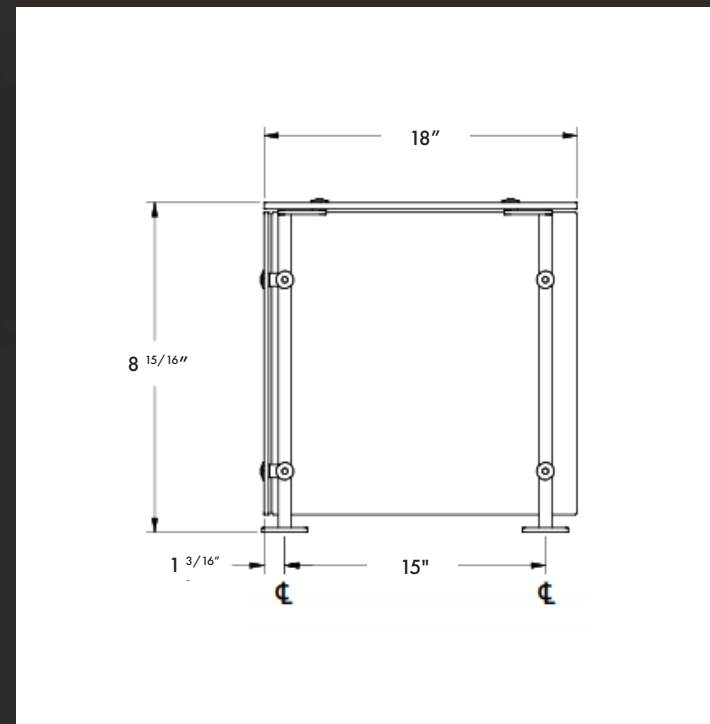

**V4-CR**



Compatible with model(s): V4D, V4ED, V10D

**CONNKT**  
POST

**V4-LF**



Compatible with model(s): V4, V4D

**V4-LFE**



Compatible with model(s): V4E, V4ED

**V4-R**



Compatible with model(s): V4, V4D

**V4-RFE**



Compatible with model(s): V4E, V4ED

**V4-LRE**



Compatible with model(s): V4E, V4ED

**V4-RRE**



Compatible with model(s): V4E, V4ED

**V4-CF**



Compatible with model(s): V4D, V4ED

**V4-RF**



Compatible with model(s): V4, V4D

**V5- VERTICAL, OPERATOR-SERVE FOOD SHIELD**

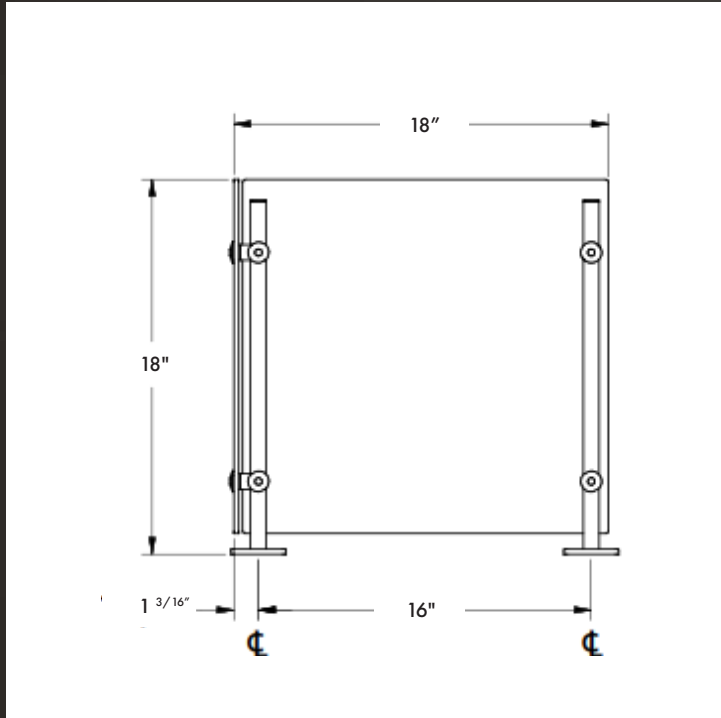

**V5-CF**



Compatible with model(s): V5D, V5ED

**V5-LFE**



Compatible with model(s): V5E, V5ED

**V5-RF**



Compatible with model(s): V5, V5D

**V5-E**



Compatible with model(s): V5, V5EM

**V5-LF**



Compatible with model(s): V5, V5D

**V5-RFE**



Compatible with model(s): V5E, V5ED

**V6- VERTICAL, OPERATOR-SERVE FOOD SHIELD**

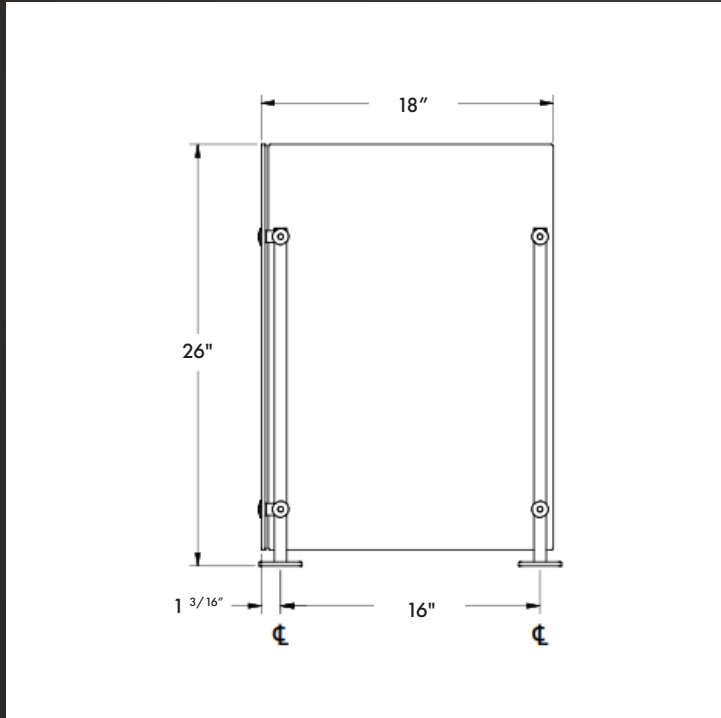

**V6-CF**



Compatible with model(s): V6D, V6ED

**V6-LFE**



Compatible with model(s): V6E, V6ED

**V6-RF**



Compatible with model(s): V6, V6D

**V6-E**



Compatible with model(s): V6E

**V6-LF**



Compatible with model(s): V6, V6D

**V6-RFE**



Compatible with model(s): V6E, V6ED

**V10- CONVERTIBLE FOOD SHIELD**

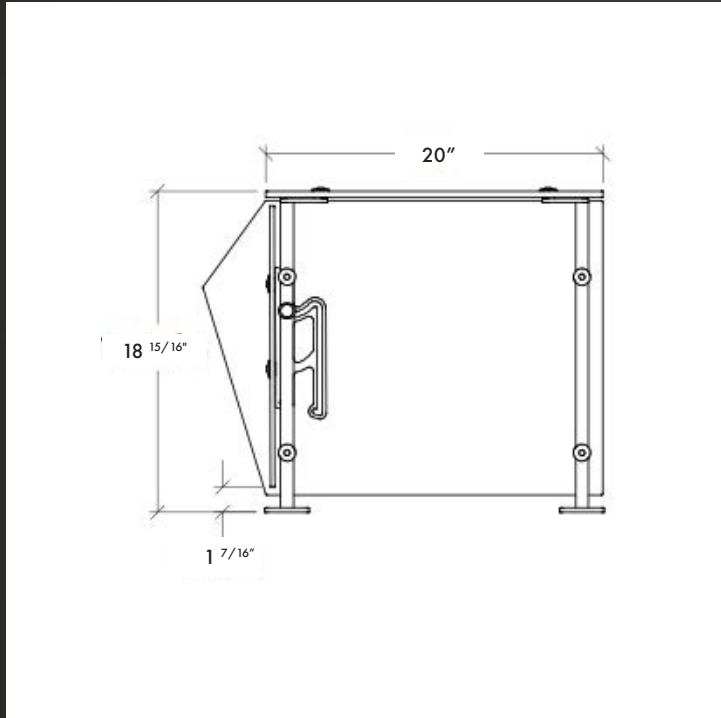

**V10-CF**



Compatible with model(s): V10D

**V10-RFE**



Compatible with model(s): V10, V10D

**V10-RRE**



Compatible with model(s): V10, V10D

**V10-LFE**



Compatible with model(s): V10, V10D

**V10-LRE**



Compatible with model(s): V10, V10D

# MODELS

## V1

Adjustable Food Shield

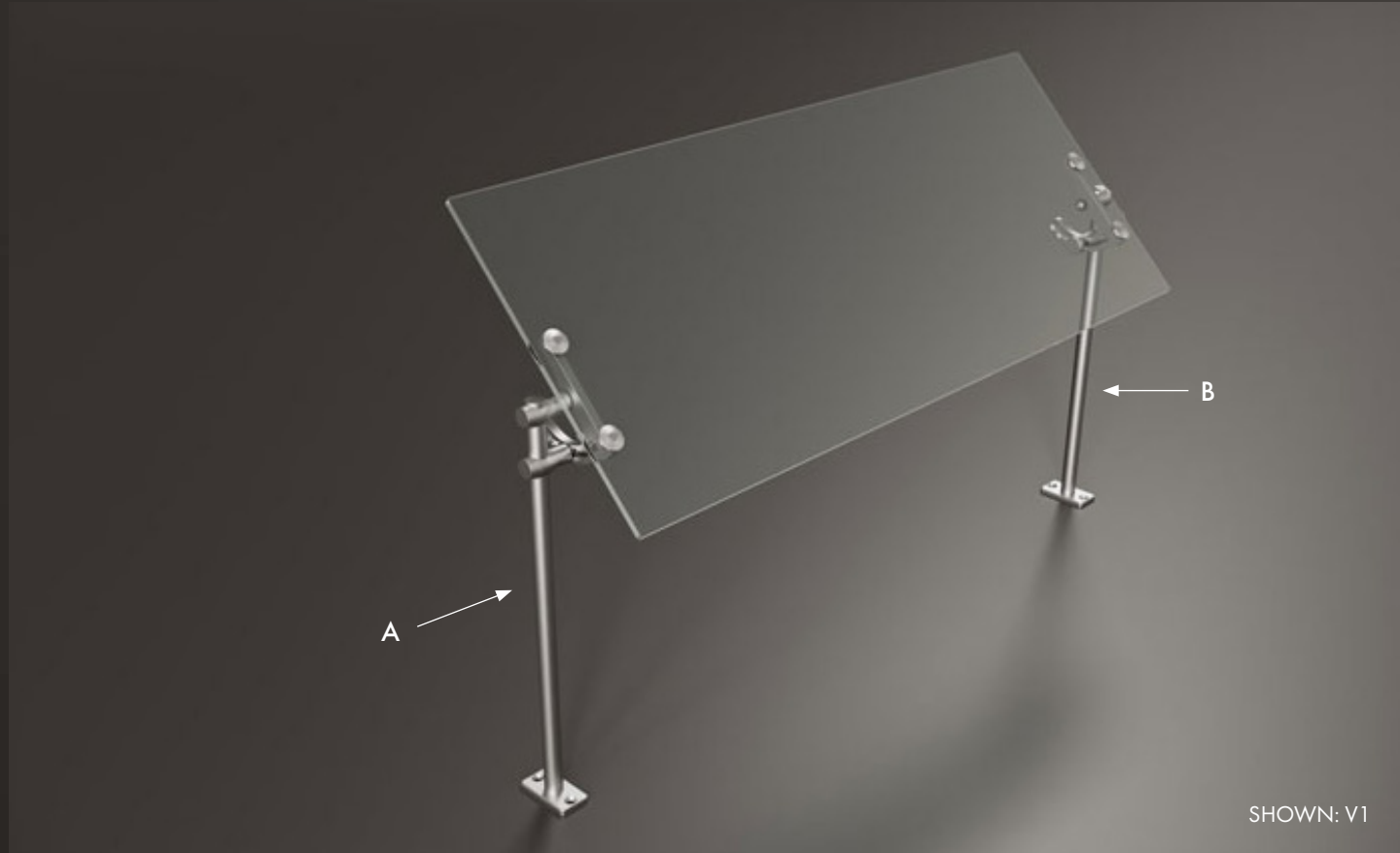

Basic self-service food shield with adjustable panel

MODEL	BAYS
V1	SINGLE
V1D	DOUBLE
V1E	SINGLE
V1ED	DOUBLE

## V2

Single Sided, Self-Serve Adjustable Food Shield

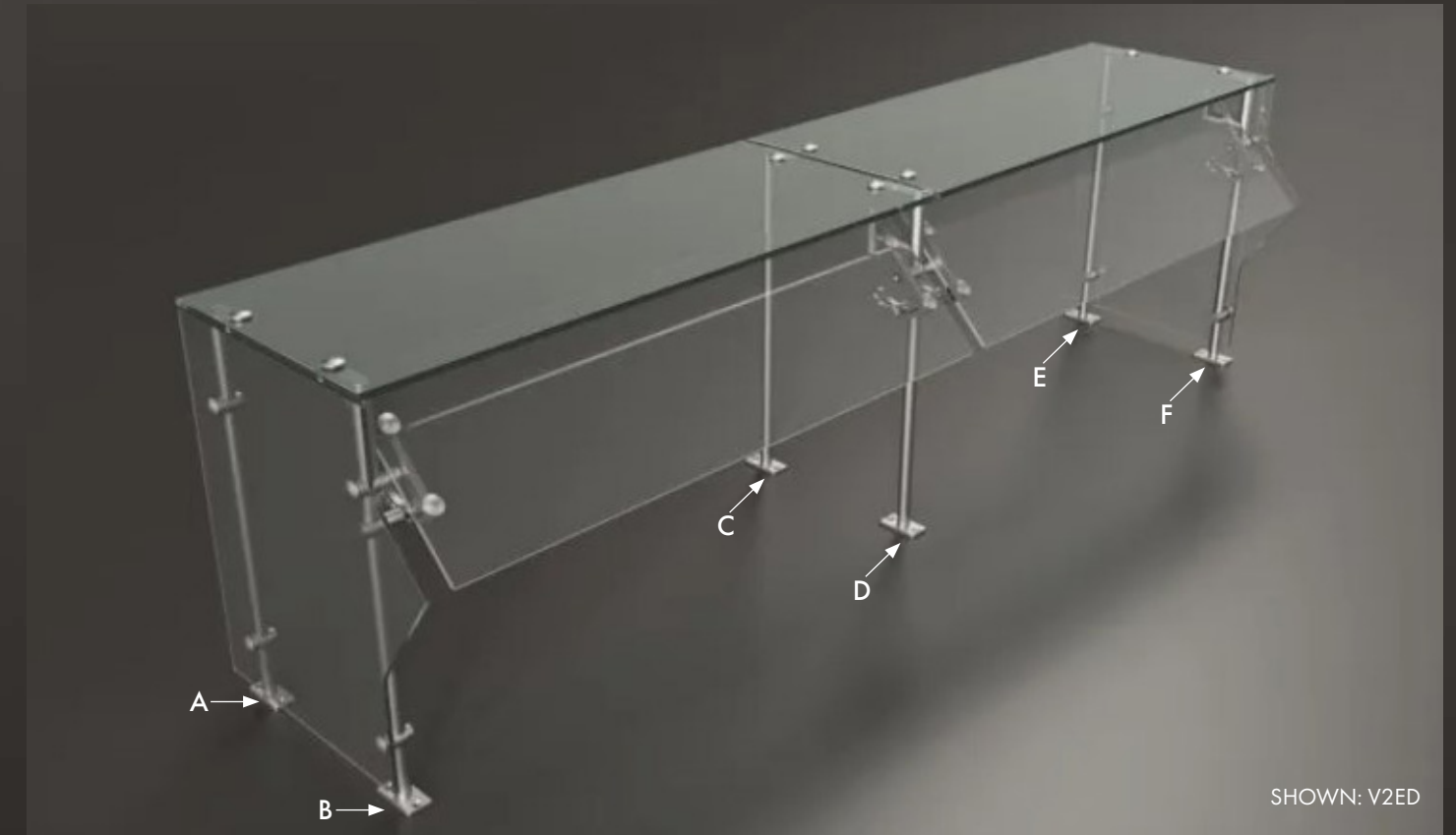

Adjustable self-service food shield with a top shelf for pass-over or display

MODEL	BAYS
V2	SINGLE
V2E	SINGLE
V2D	DOUBLE
V2ED	DOUBLE

### V3

#### Double Sided Self-Serve Adjustable Food Shield

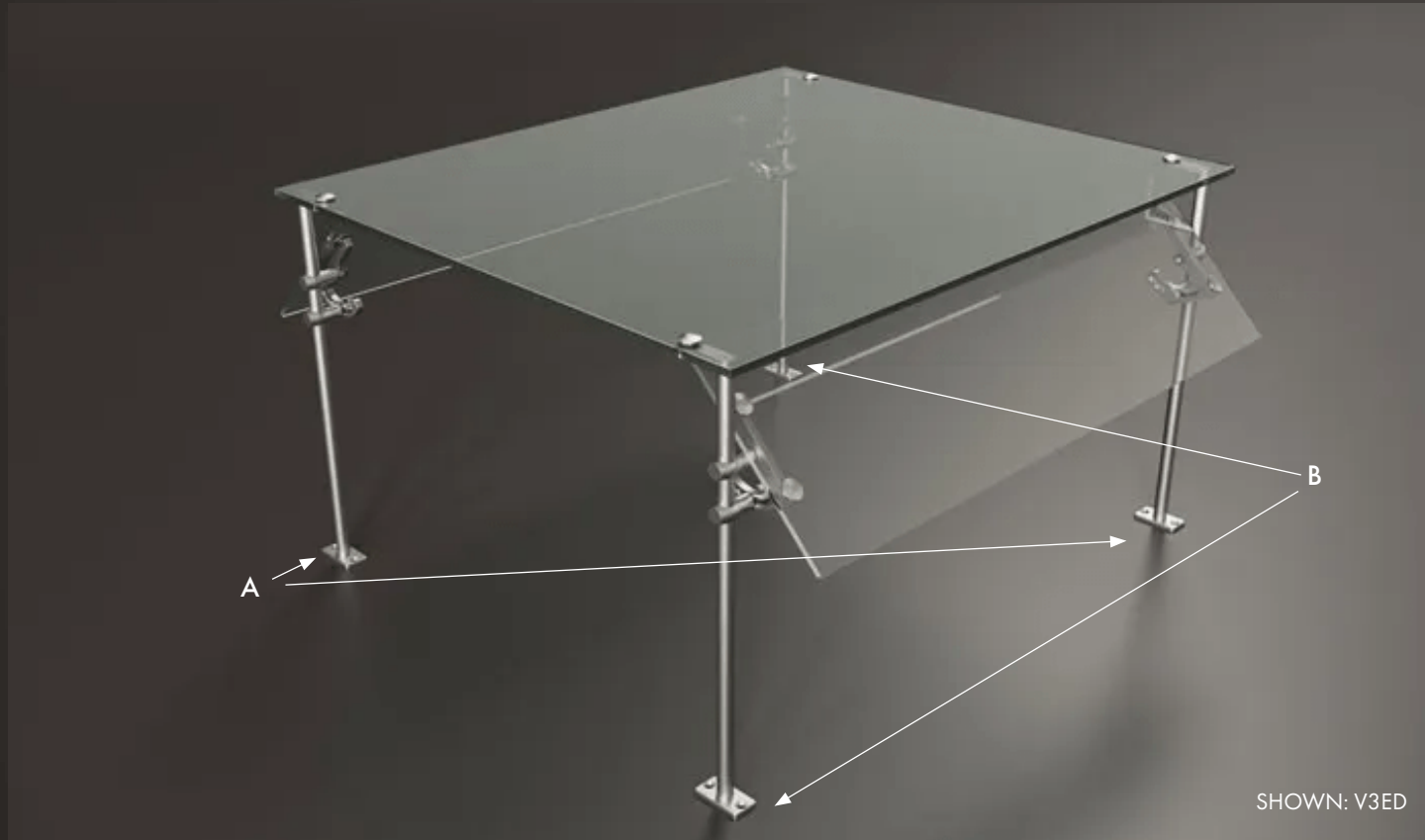

Dual-sided, adjustable self-service food shield with a top shelf

MODEL	BAYS
V3	SINGLE
V3E	SINGLE
V3D	DOUBLE
V3ED	DOUBLE

### V4

#### Enclosed Operator-serve Food Shield

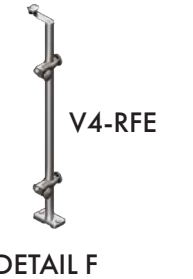
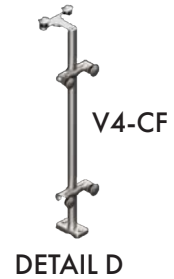
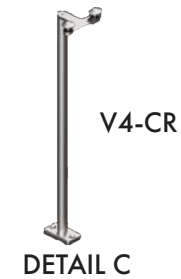
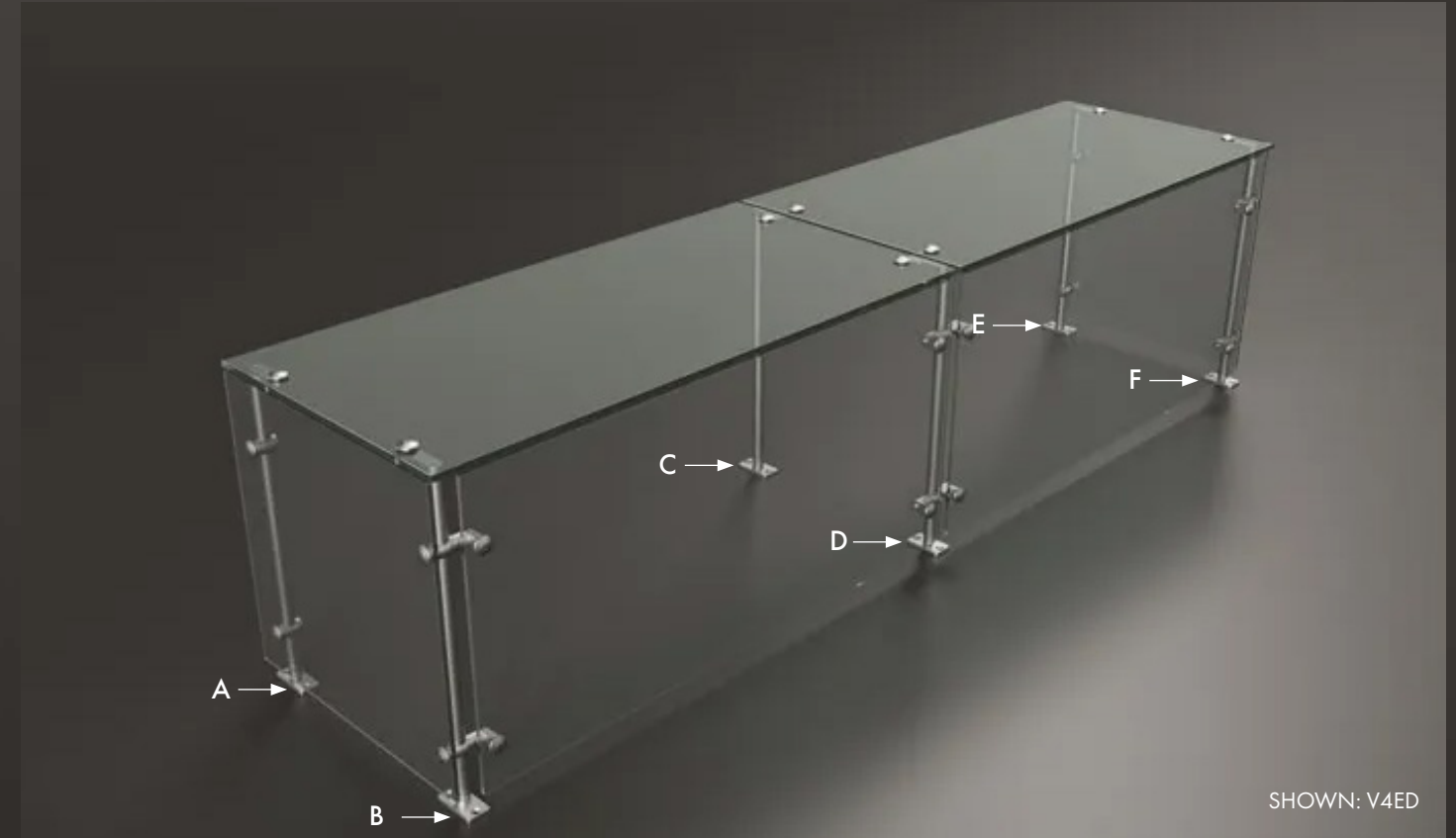

Fully enclosed food shield with a display shelf for operator-served applications

MODEL	BAYS
V4	SINGLE
V4E	SINGLE
V4D	DOUBLE
V4ED	DOUBLE

## V5

Vertical, Operator-serve Food Shield

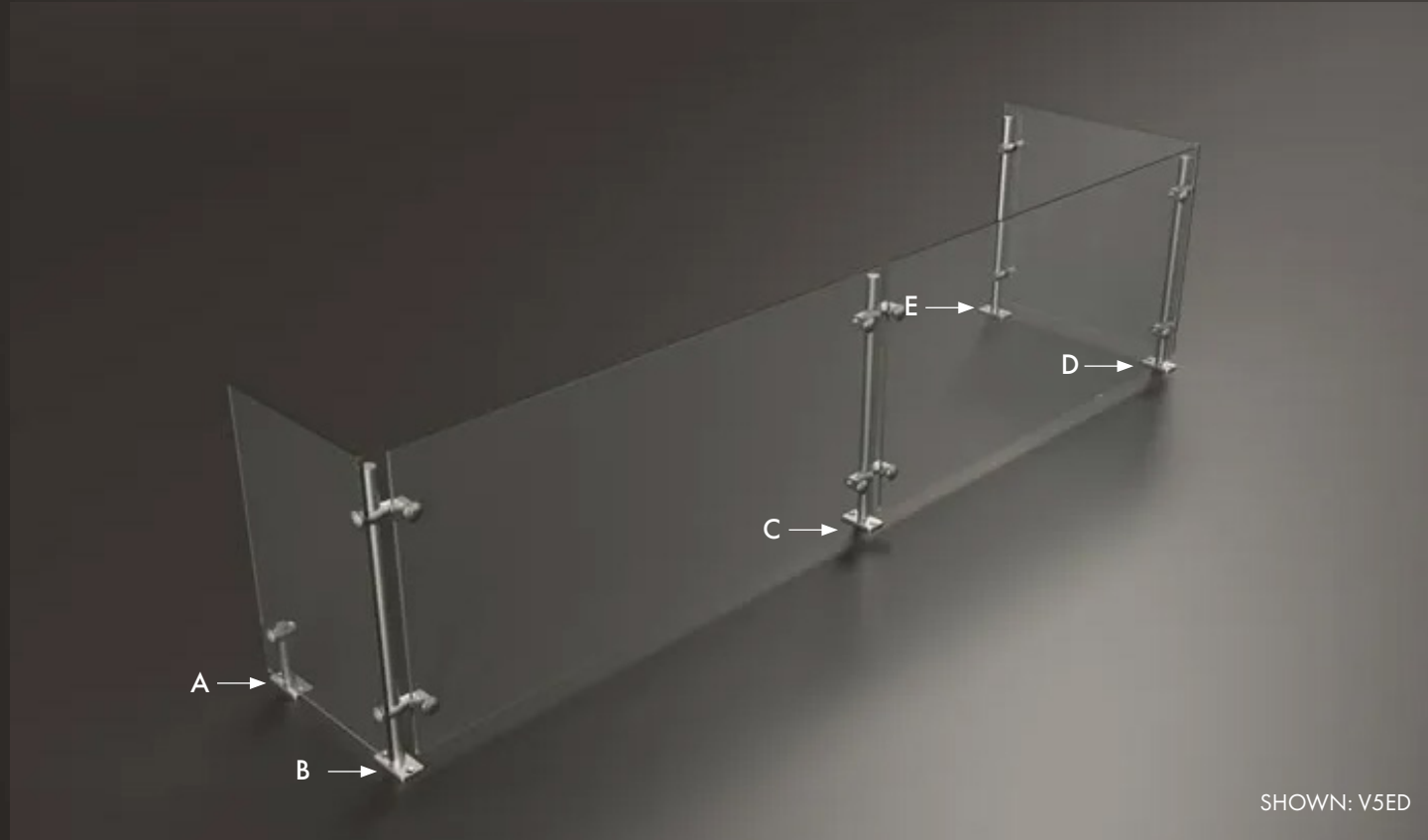

## V6

Vertical, Operator-serve Food Shield

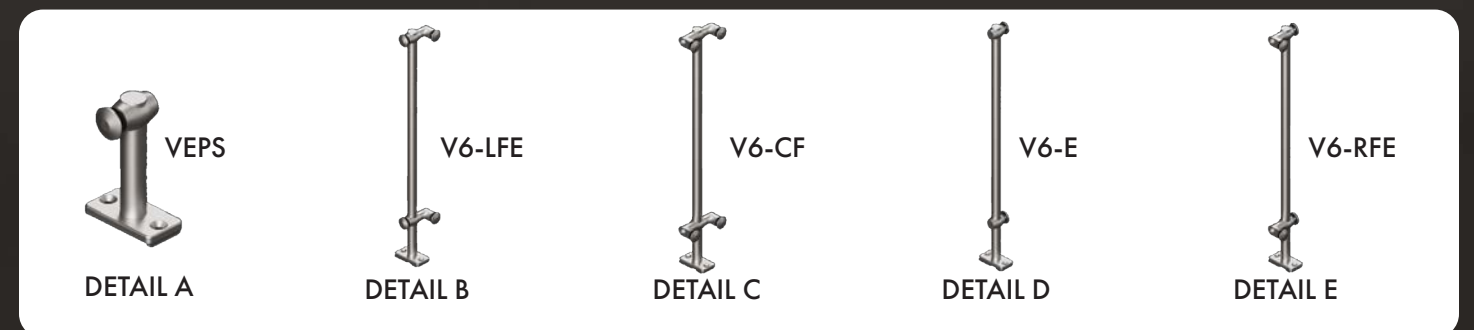
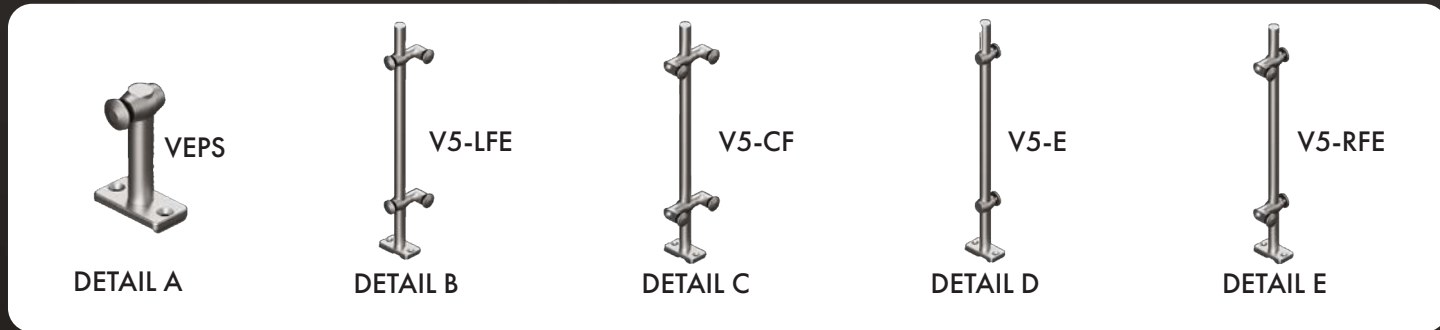
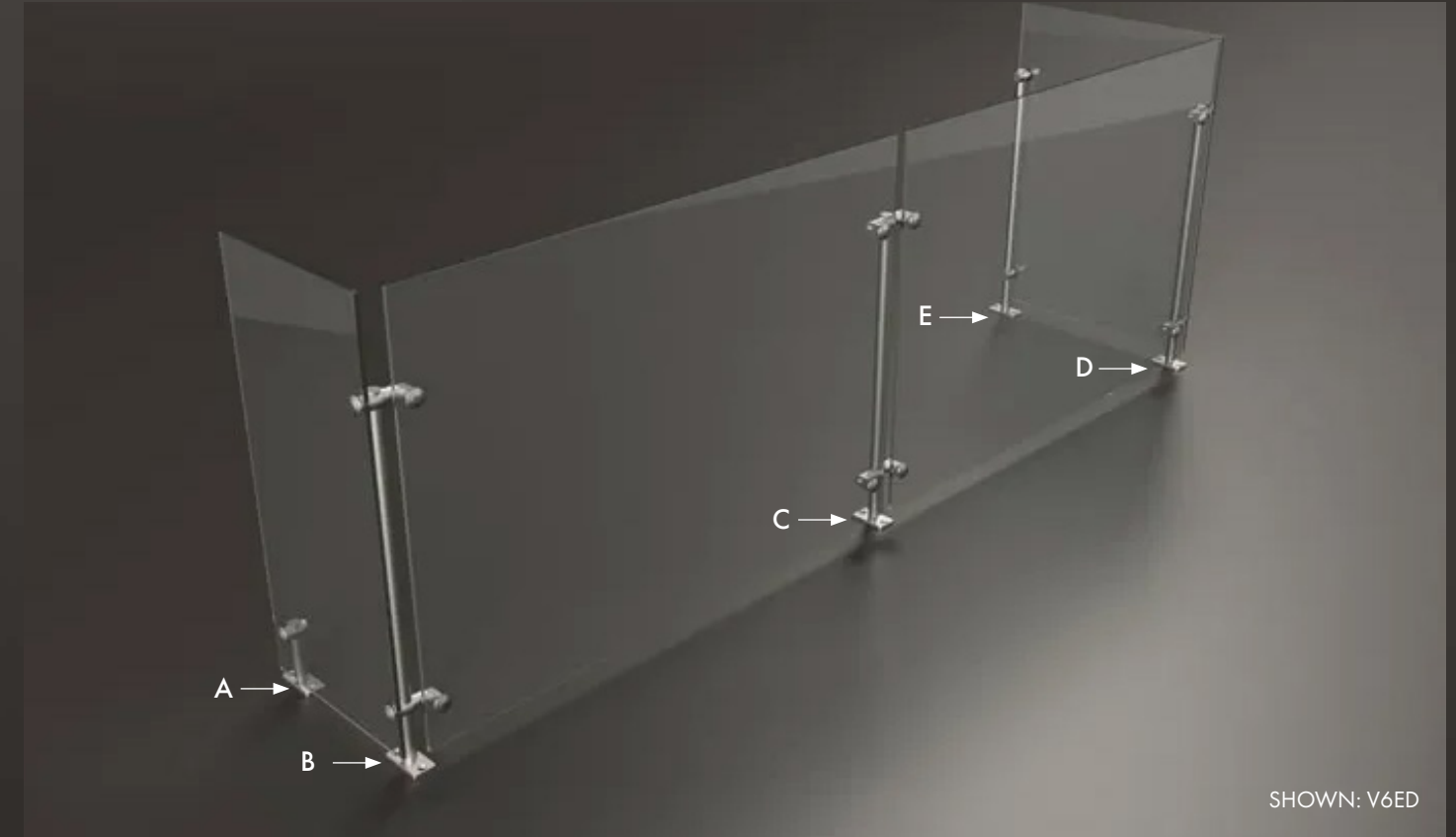

Vertical food shield for counters or knee-walls at 42" or taller

MODEL	BAYS
V5	SINGLE
V5E	SINGLE
V5D	DOUBLE
V5ED	DOUBLE

Vertical food shield for counters between 34" and 36"

MODEL	BAYS
V6	SINGLE
V6E	SINGLE
V6D	DOUBLE
V6ED	DOUBLE

# V10

## Convertible Food Shield

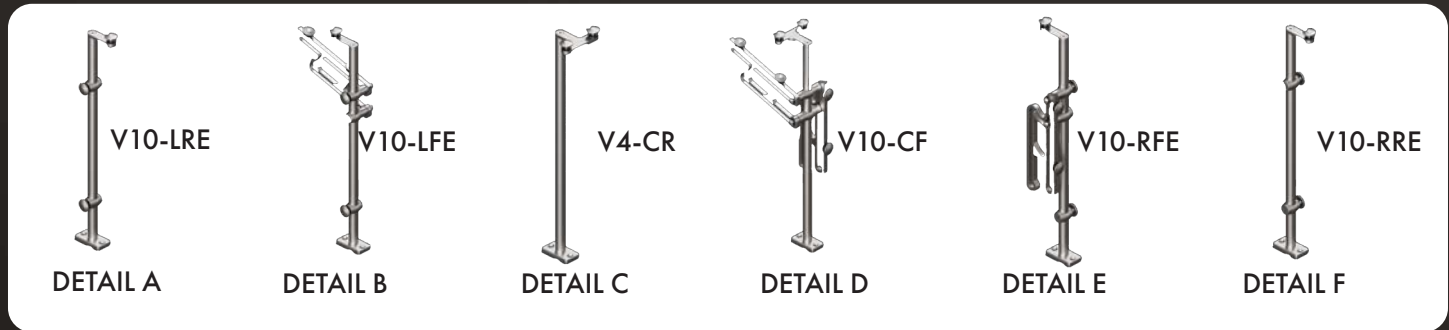

Convertible food shield adjusts from self-service to operator-service with a top shelf for pass-over or display

MODEL	BAYS
V10	SINGLE
V10D	DOUBLE



CONNEXT  
POST

connektsneezeguards.com  
info@connektsneezeguards.com  
+1 678 765 2224

